

Three-Point 50mm Tow-bar

The 3 point linkage tow bar makes lifting your trailer easy. Ultra strong design makes the tow ball easily visible from the drivers seat of your tractor. Robust all-steel construction makes it easier to connect and remove from your tractor. Can also be used to raise your drawbar on your boat trailer to drain water from your boat after a day fishing.

Tow your trailer around your paddock or farm to move water & diesel tanks, chainsaws, toolboxes, stock feed, small tanks, hay, hoses, generators... Take advantage of your tractor's rear end and lift the tow bar up and down hydraulically - no more sore back! The 3-Point towbar has got you covered... Suits any trailer with a 50mm tow hitch. Strong steel frame, dual category options, easy to attach, a breeze to store. Optionally swap the ball for a conventional drop pin.

 Category #1
3 Point Linkage

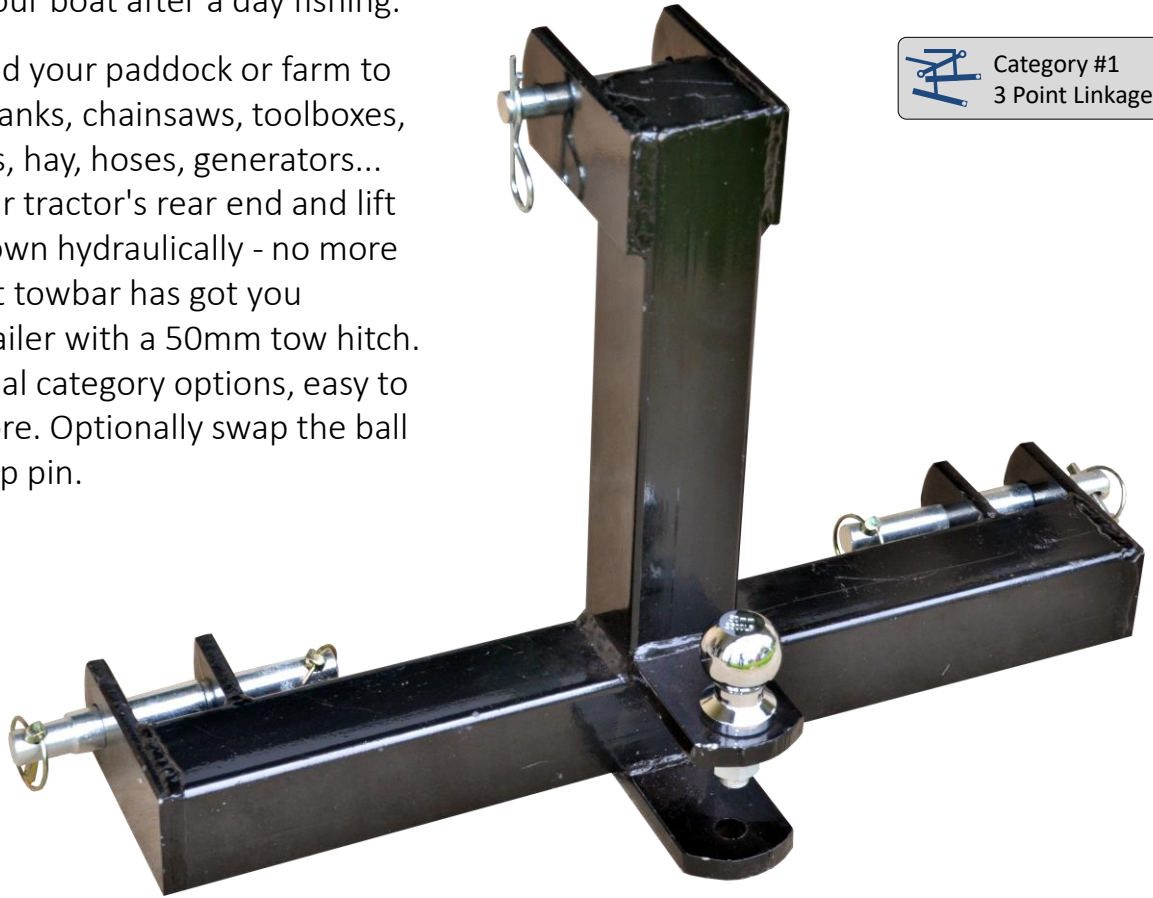

Hitch	3 Point Linkage
Hitch Spacing	440mm - 900mm
Category	1 & 2 (Sliding Pins)
Tractor Power Required	10 HP +
Tow Ball Size	50mm
Tow Ball Shank	25mm
Tow Ball Capacity	3,500kg
Drop Pin Compatible	Yes
Width	790mm
Height	470mm
Depth	280mm

Your Price



Inc. GST



- Chat to Normal, Friendly Folk
- 100% Australian Family Owned
- Factory Direct Products
- Readily Available Spare Parts
- Reliable After Sales Service

 **www.DiscountImplements.com**

 **(02) 6553 6393**

 **The Lakes Way, Rainbow Flat, NSW 2430**

Discount Implements is a subsidiary of Discount Rural. Full specifications are available on our website. All prices are inclusive of GST. Warranty is strictly back-to-base. For full terms and conditions for the warranty, please visit our warranty page. *Offers, inclusions and accessories are available only while stocks last and are subject to availability. Offers and/or included accessories may be withdrawn or changed without prior notice. Included bonuses may be changed for an alternative of lesser retail value at agents discretion. Package deal price(s) available only at designated marketing events or at dealers discretion. Prices and specifications correct at time of publication but are subject to change and/or correction without prior notice. Implements with gearboxes (ie. Connect to the tractor with a PTO shaft) do not contain oil when new - add gear oil before use. Some assembly is required. Gear oil not included. For our full Warranty Policy, please visit <https://www.discountimplements.com>